

## CPX Behälter 25L rechteckig

Der Tank hat zwei integrierte Tragegriffe zur einfachen Handhabung. Standardmäßig mit 225-mm-Spanndeckel mit O-Ring. Der Behälter ist stapelbar.

Auch in einer höheren 50-Liter-Ausführung erhältlich (200504).

Der Behälter kann nach Wunsch mit Anschlüssen versehen werden.

Art.-Nr.: 200264



Benötigt Einzeltür



Ungefähre Größe

### Spezifikationen

Material	PE
Form	Rechteckig
Untere Form	Plan
Leistung	Geschlossen
Art des Deckels	
Farbe	Natürlich
Volumen (L)	25
Länge (mm)	350
Breite (mm)	350
Höhe (mm)	320
Grundfläche (m <sup>2</sup> )	0,13
Gewicht (kg)	2,5
Statistische Zollnummer	3925100000
GTIN	7090046760603
Recycling	

### Eigenschaften



Anpassbar



Recyclbar



Großer  
Temperaturberei-  
ch



Chemikalienbest-  
ändig



Dichtigkeitsprüf-  
ung



Logistiklösung



An Lebensmittel  
angepasst



Einfach zu  
reinigen

Gedruckt 10.05.2024

Revision		
REV.	Ändringsmeddelande	Datum
		Godkänd

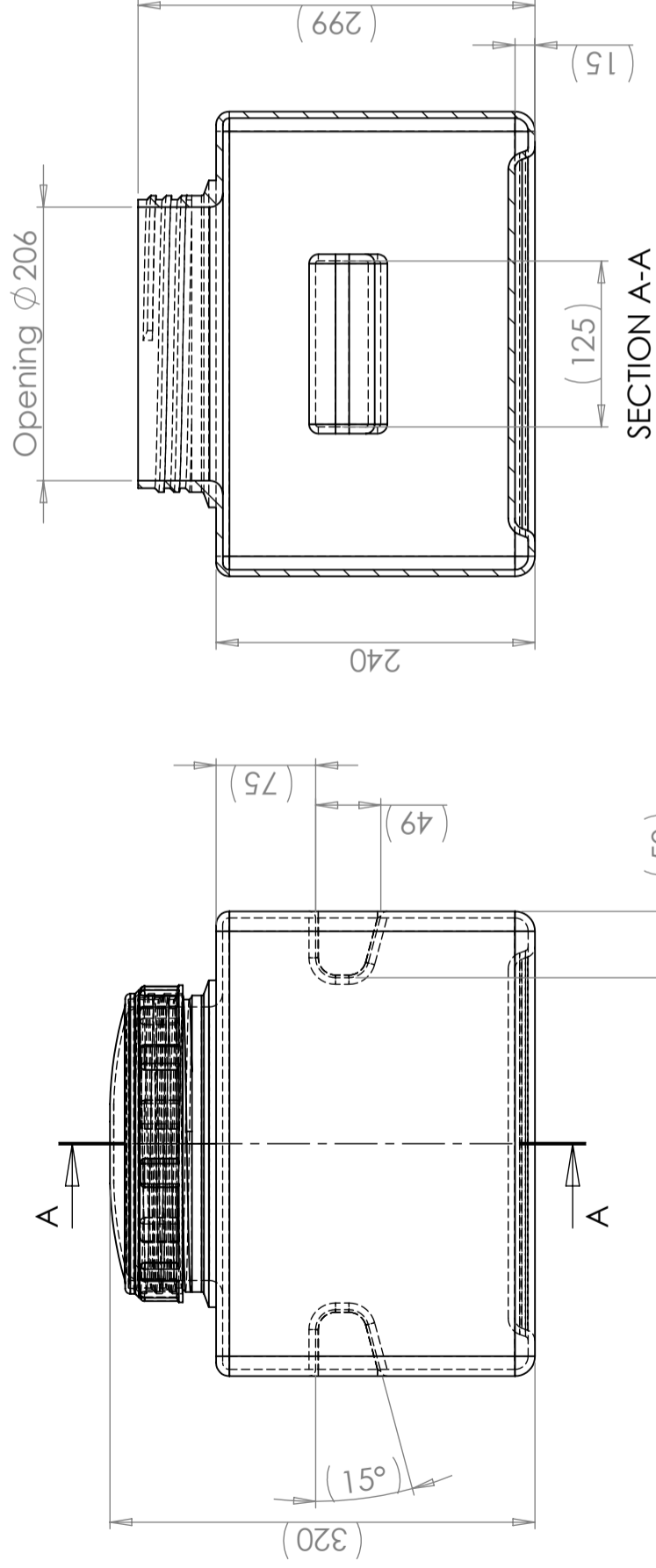

Cipax 63717  
Cipax 63718

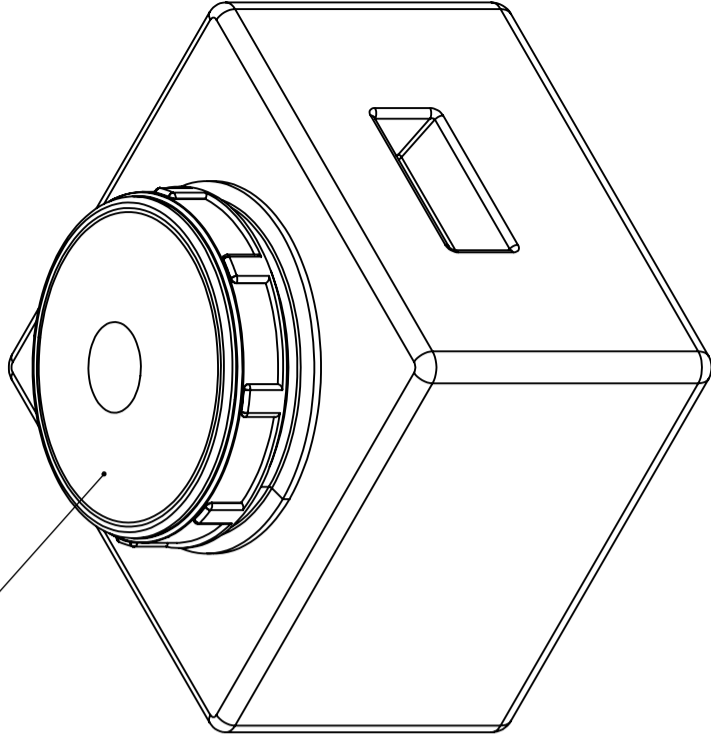
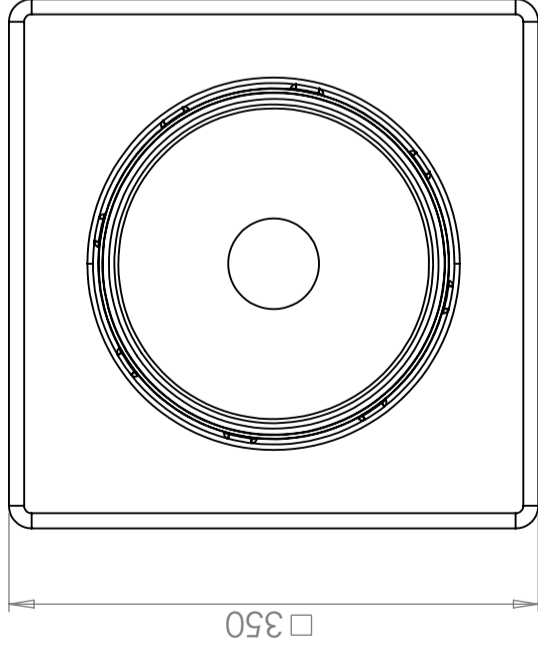

This drawing and design is the property of Cipax. Copying and distribution of the drawing or any contents is prohibited without written permission from authorised personal at Cipax

Konstruerad av <b>MB</b>	Granskad av <b>FB</b>	Godkänd av - datum <b>2023-11-07</b>	Generell tolerans SS-ISO 2768-1	Generell Ytjämnhet, Ra	Vyplacering	Skala <b>1:5</b>
Ägare						
Titel/Benämning <b>CPX container 25L rectangular w/ 240 screw cap</b>			Ritningsnummer <b>200264</b>	Utgåva <b>A</b>	Blad <b>1(1)</b>	

Generella toleranser omej annat anges på ritning	Tillåtna avvikelser för längdbasområde. Gäller + 20°C
General tolerances if not other stated on drawing	Permissible deviations for basic length size range. Be valid + 20°C
± 0,5 mm	0-20
± 1 mm	>20-75
± 1,5 mm	>75-150
± 1,3 %	>150-300
± 1 %	>300