



## CPX Mooring bouy MB 240L natural incl rod

Örnbojen hat eine äußere Schale aus schlagfestem Polyethylen-Kunststoff, die mit freon-freiem Polystyrol-Schaum gefüllt ist. Lochdurchmesser 80 mm

Art.-Nr.: 30090

Spezifikationen	
Material	PE
Farbe	Natürlich
Volumen (L)	240
Höhe (mm)	750
Durchmesser (mm)	720
Lochdurchmesser (mm)	80
Gewicht (kg)	40
Recycling	

## Eigenschaften



Anpassbar



Recyclebar



Großer  
Temperaturbereich



An Lebensmittel  
angepasst



Einfach zu  
reinigen

Ändrings Nr	Ändringens art / Ändringsmeddelande	Godkänd av	Datum
1	Material spec. förtydligad	SE	2006-11-27
2	Hål 14 (4x) position förtydligad	SE	2010-10-14
3	Toppöglan ändrad	SE	2011-01-24

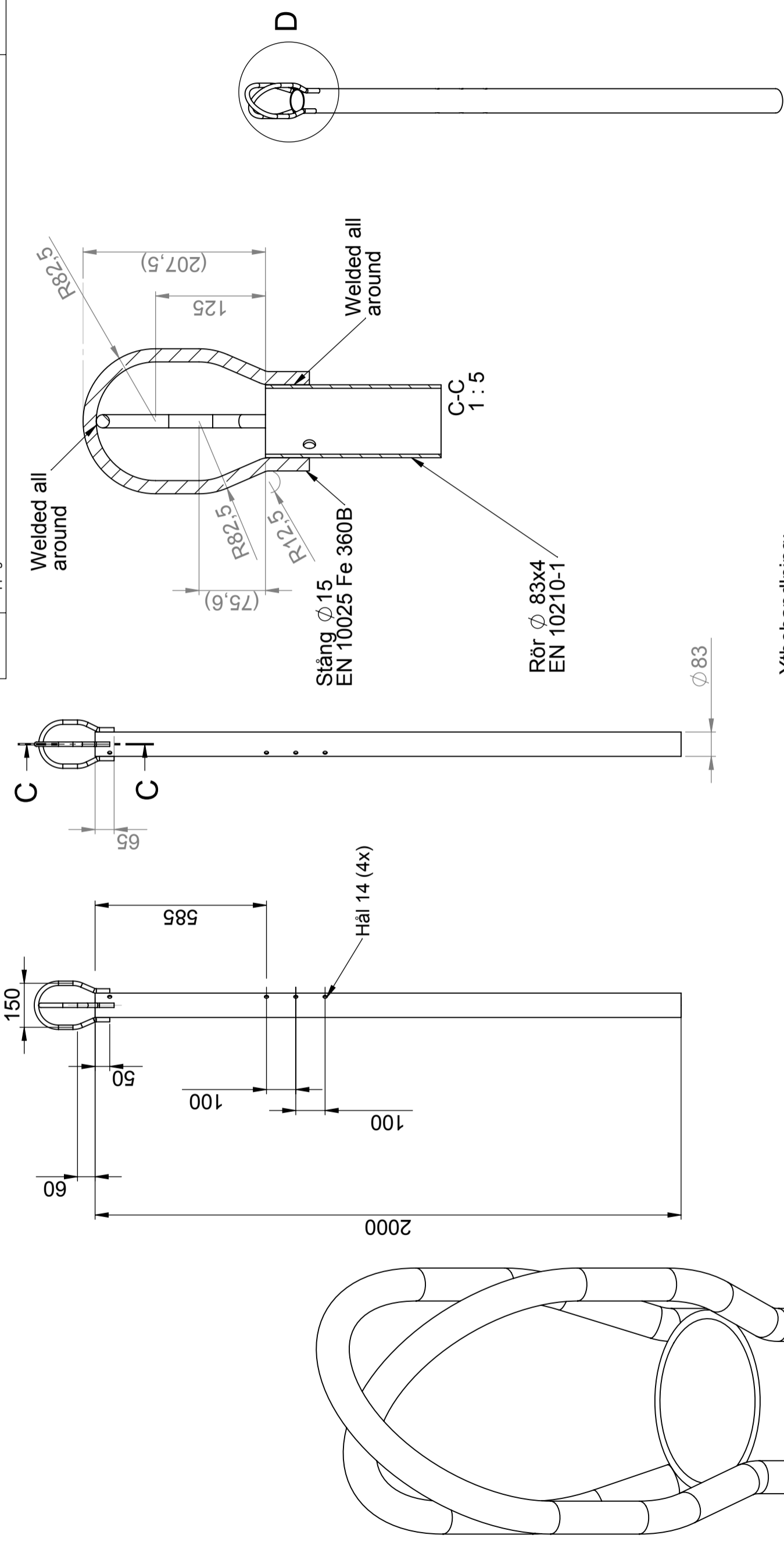

Ytbehandling:  
Fe/Zn 115 ISO 1461

Ten 62230 komplett levereras med:  
1 st Platta 62280  
2 st Bult M12x100 M6S FZV DIN 931/150 ISO 4014  
2 st Mutter M12 loc-king LM6M FZV DIN 985

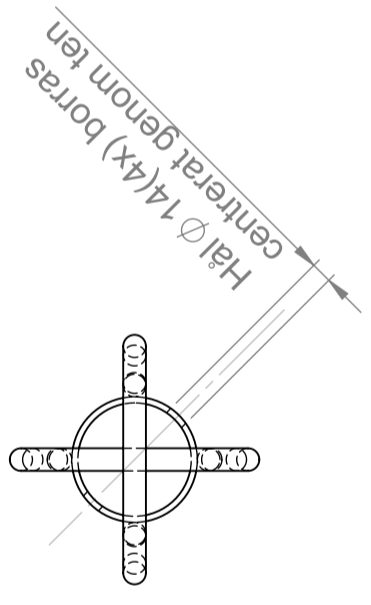

DETAIL D  
1:2

Konstruerad av SE	Granskad av SE	Godkänd av - datum SE - 2006-09-25	Generell tolerans SS-ISO 2768-1	Generell Ytjämnhet, Ra	Vyplacering	Skala 1:20
Titel/Benämning Ten 280 liter 62230						
Ritningsnummer S3-2806						
Utgåva 3						Blad 1(1)

