

## CPX Container 25L rechthoekig

De tank heeft twee geïntegreerde draaggrepen voor eenvoudig hanteren. Standaard met een O-ring afgedicht klemdeksel van 225 mm. De container is stapelbaar.

Ook verkrijgbaar in een hogere uitvoering met een inhoud van 50 L, 200504.

De container kan worden voorzien van aansluitingen, geheel volgens uw wensen.

Art.nr.: 200264



Vereist enkele  
deur



Grootte ongeveer

### Specificaties

Materiaal	PE
Model	Rechthoekig
Bodem	Vlak
Uitvoering	Gesloten
Type deksel	
Kleur	Naturel
Inhoud (L)	25
Lengte (mm)	350
Breedte (mm)	350
Hoogte (mm)	320
Vloeroppervlak (m <sup>2</sup> )	0,13
Gewicht (kg)	2,5
Dichtheid inhoud (max kg/l)	1,2
Statistisch nummer van de douane	3925100000
GTIN	7090046760603

Recycling



### Eigenschappen



Aanpasbaar



Recyclebaar



Breed  
temperatuurbereik:



Bestand tegen  
chemicaliën



Lek testen



Logistieke  
oplossing



Aangepast voor  
eten



Makkelijk  
schoon te  
maken

Gedrukt 27-09-2024

Revision		
REV.	Ändringsmeddelande	Datum
		Godkänd

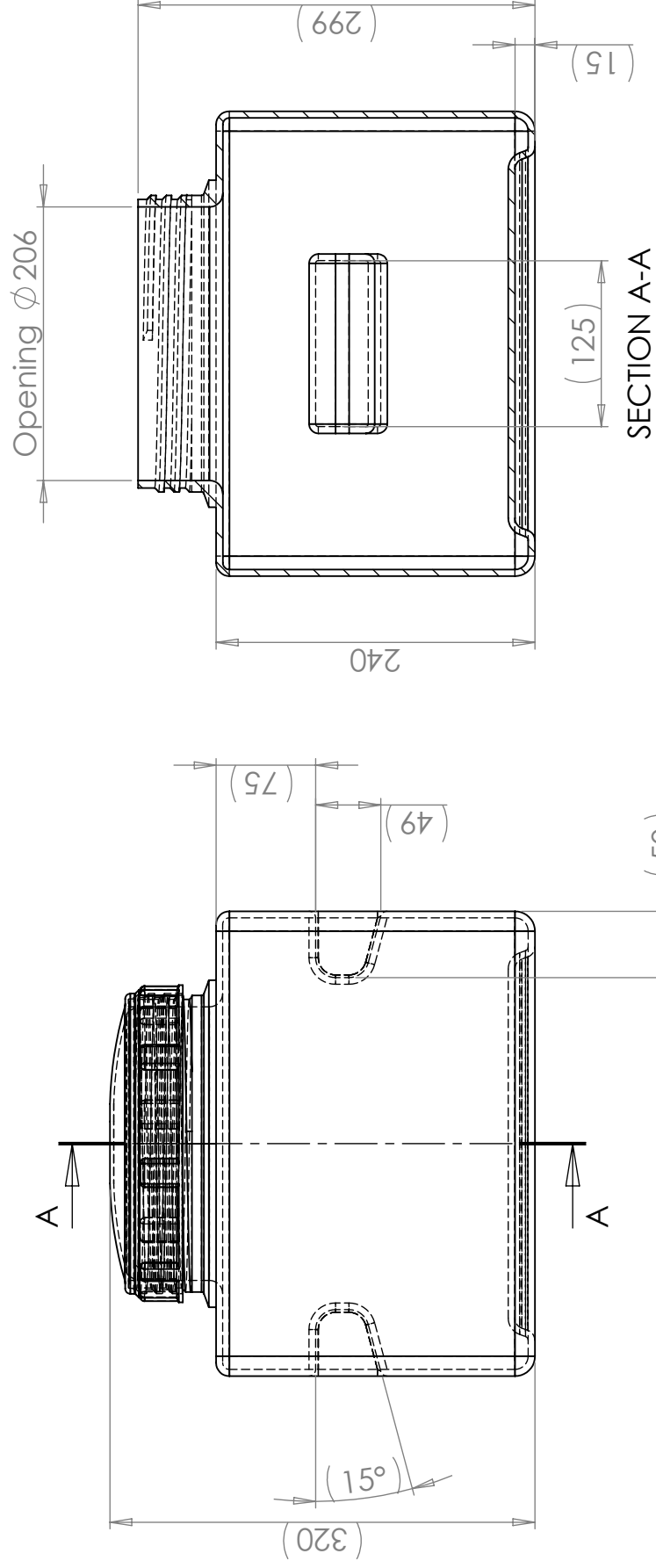

Cipax 63717  
Cipax 63718

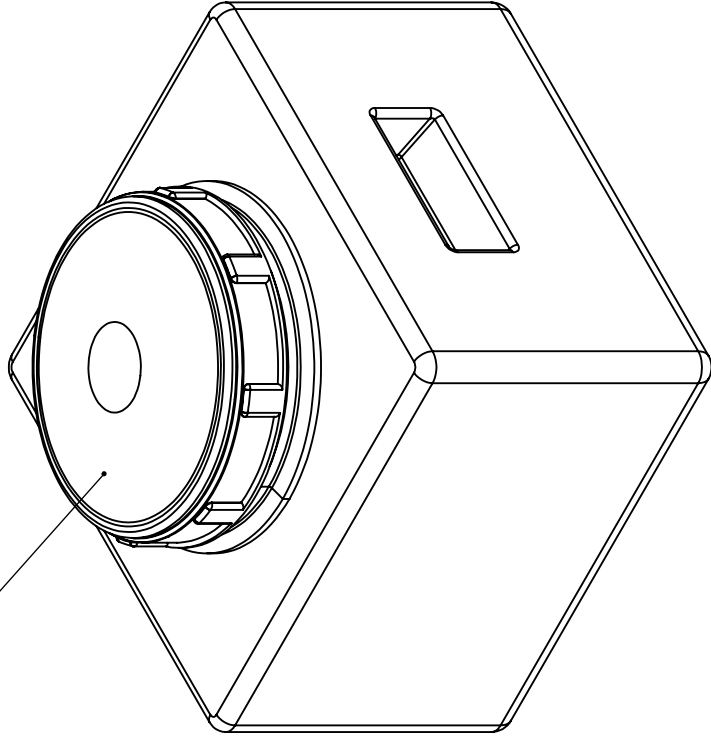
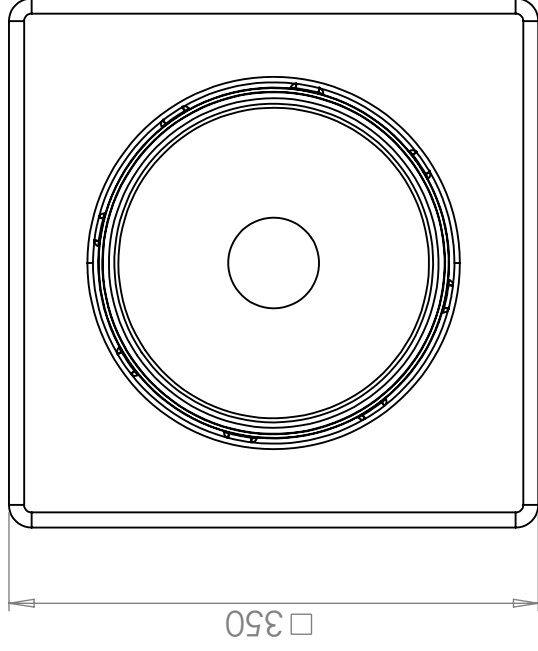

This drawing and design is the property of Cipax. Copying and distribution of the drawing or any contents is prohibited without written permission from authorised personal at Cipax

Konstruerad av <b>MB</b>	Granskad av <b>FB</b>	Godkänd av - datum <b>2023-11-07</b>	Generell tolerans SS-ISO 2768-1	Generell Ytjämnhet, Ra	Vyplacering	Skala <b>1:5</b>
Titel/Benämning <b>CPX container 25L rectangular w/ 240 screw cap</b>			Ritningsnummer <b>200264</b>	Utgåva <b>A</b>	Blad <b>1(1)</b>	

Generella toleranser omej annat anges på ritning	Tillåtna avvikelser för längdbasområde. Gäller + 20°C
General tolerances if not other stated on drawing	Permissible deviations for basic length size range. Be valid + 20°C
± 0,5 mm	0-20
± 1 mm	>20-75
± 1,5 mm	>75-150
± 1,3 %	>150-300
± 1 %	>300

