

## CPX Container 50L rechthoekig



De tank heeft twee geïntegreerde draaggrepen voor eenvoudig hanteren. Standaard met een O-ring afgedicht klemdeksel van 225 mm.

De container is stapelbaar. De container kan worden voorzien van aansluitingen, geheel volgens uw wensen.

Ook verkrijgbaar in een lagere uitvoering met een inhoud van 25 L, 200264.

Art.nr.: 200504



Vereist enkele  
deur



Grootte ongeveer

### Specificaties

Materiaal	PE
Model	Rechthoekig
Bodem	Vlak
Uitvoering	Gesloten
Type deksel	
Kleur	Naturel
Inhoud (L)	50
Lengte (mm)	350
Breedte (mm)	350
Hoogte (mm)	550
Vloeroppervlak (m <sup>2</sup> )	0,13
Gewicht (kg)	4
Dichtheid inhoud (max kg/l)	1,2
Statistisch nummer van de douane	3925100000
GTIN	7090046760641

Recycling



### Eigenschappen



Aanpasbaar



Recyclebaar



Breed  
temperatuurbereik:



Bestand tegen  
chemicaliën



Lek testen



Logistieke  
oplossing



Aangepast voor  
eten



Makkelijk  
schoon te  
maken

Revision		Godkänd	
REV.	Ändringsmeddelande	Datum	

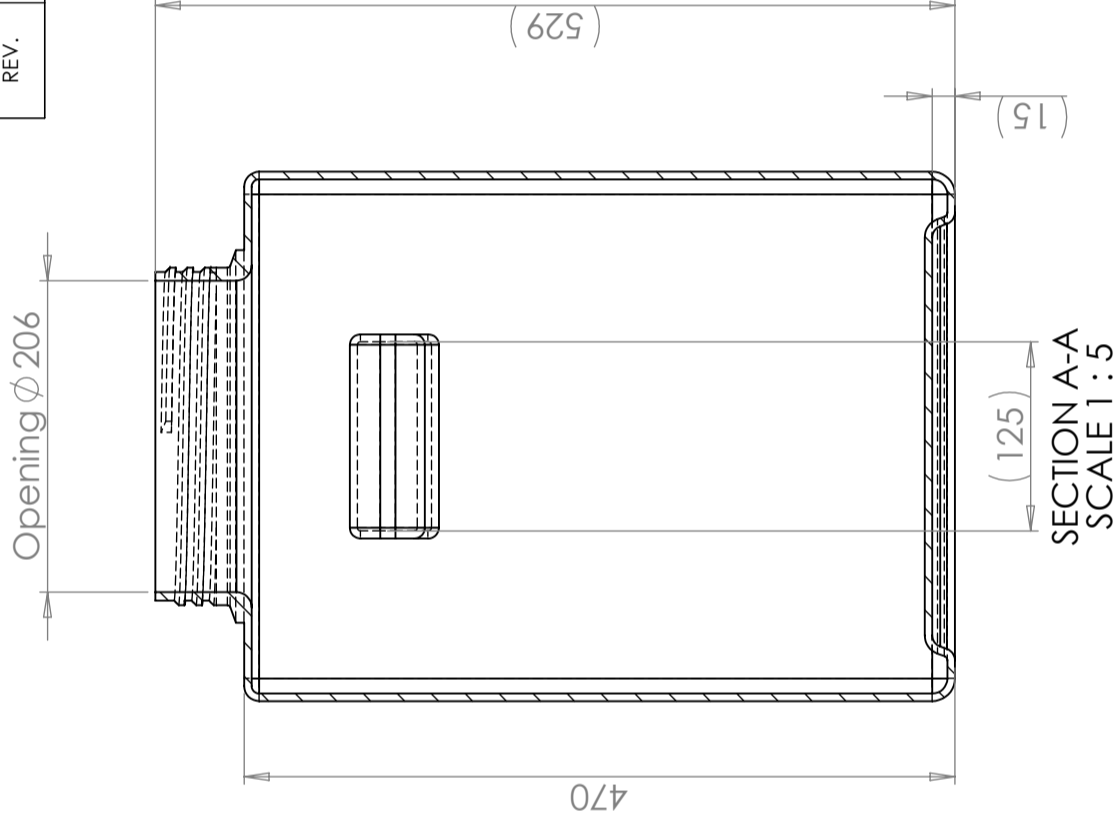
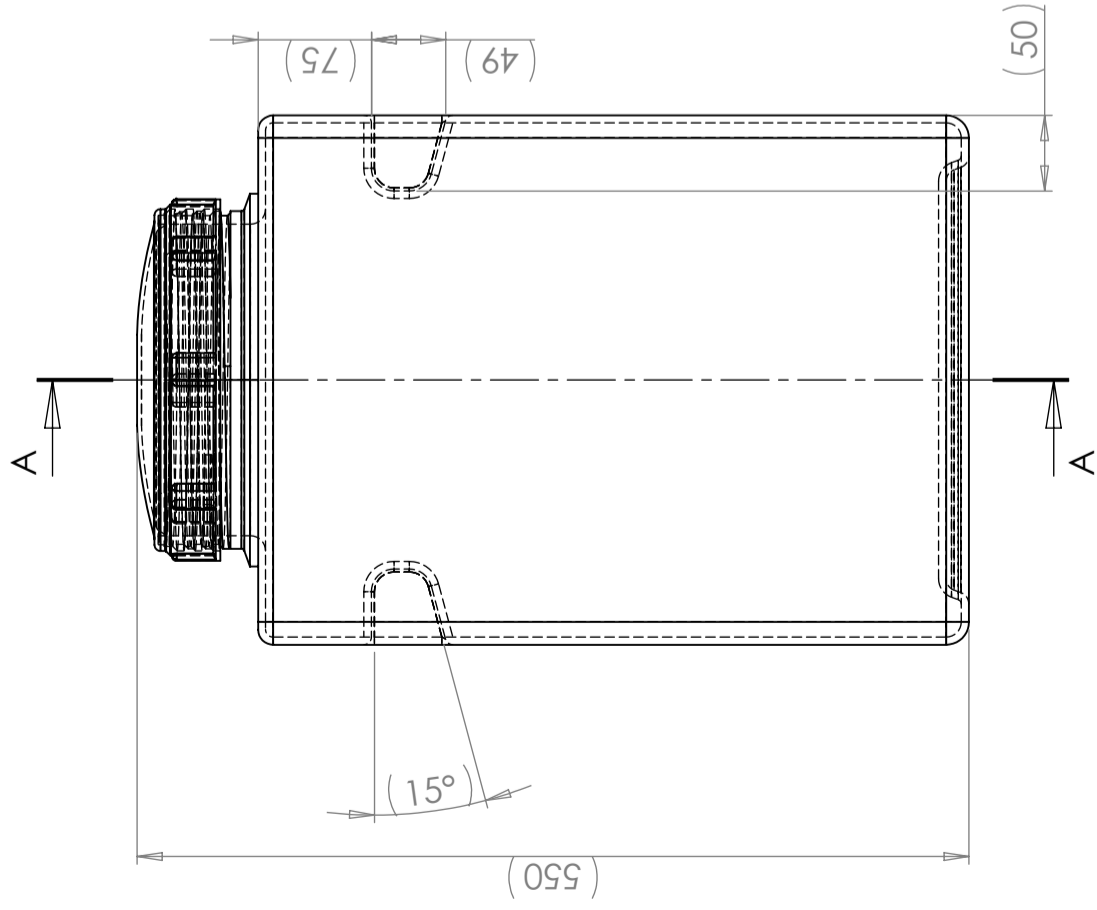

Cipax 63717  
 Cipax 63718

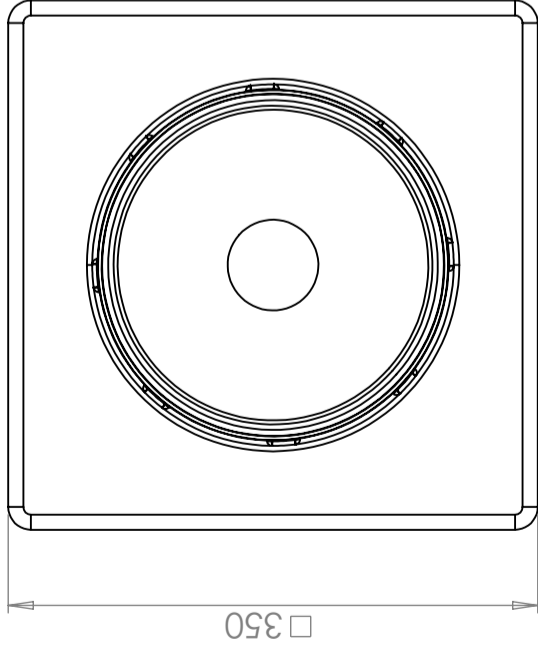
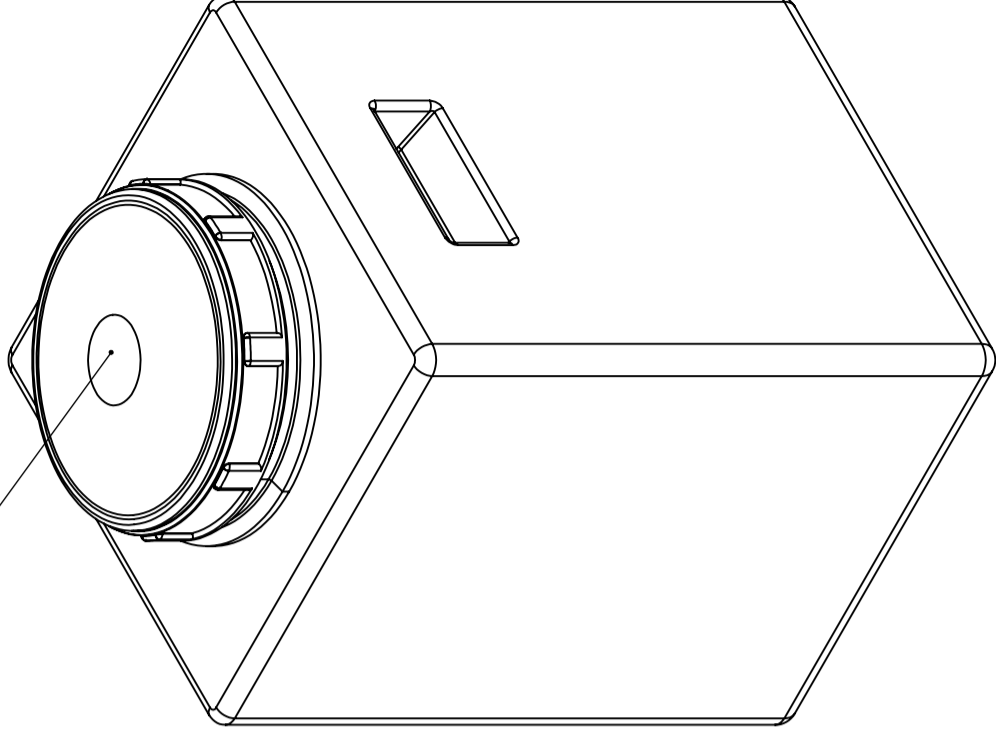

Konstruerad av <b>MB</b>	Granskad av <b>FB</b>	Godkänd av - datum <b>2023-11-07</b>	Generell tolerans SS-ISO 2768-1	Generell Ytjämnhet, Ra	Vyplacering	Skala <b>1:5</b>
Titel/Benämning <b>CPX container 50L rectangular w/ 240 screw cap</b>			Ritningsnummer <b>200504</b>	Utgåva <b>A</b>	Blad <b>1(1)</b>	

Generella toleranser om ej annat anges på ritning	Tillåtna avvikelser för längdbasområde. Gäller + 20°C			
General tolerances if not other stated on drawing	Permissible deviations for basic length size range. Be valid + 20°C			
	0-20	>20-75	>75-150	>150-300
	± 0,5 mm	± 1 mm	± 1,5 mm	± 1,3 %
				± 1 %

