



## CPX Lagringstank 10000L konisk botten

Höjd inklusive stativ: 3970 mm Höjd exklusive stativ: 3600 mm. För vätskor med densitet upp till 1,2.  
Komplekteritakse stativiga art. nr. 60386.

Art.nr: 18018



Ungefärlig storlek

### Specifikationer

Bottenform	Konisk
Volym (L)	10000
Höjd (mm)	3568
Diameter (mm)	2140
Densitet innehåll (max kg/l)	1,2
Klimatpåverkan (kg CO <sub>2</sub> -ekv.)	683

Återvinning



This drawing and design is the property of CIPAX. Copying and distribution of the drawing or any contents is prohibited without written permission from authorised personnel at CIPAX

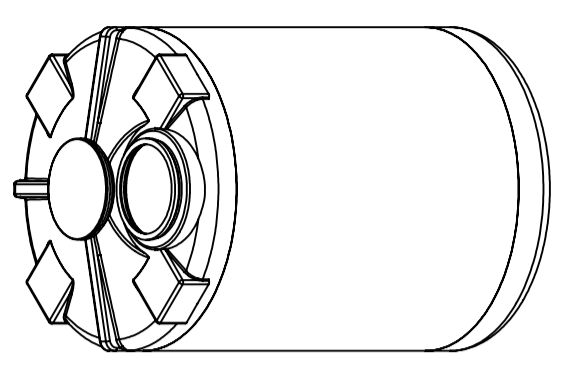
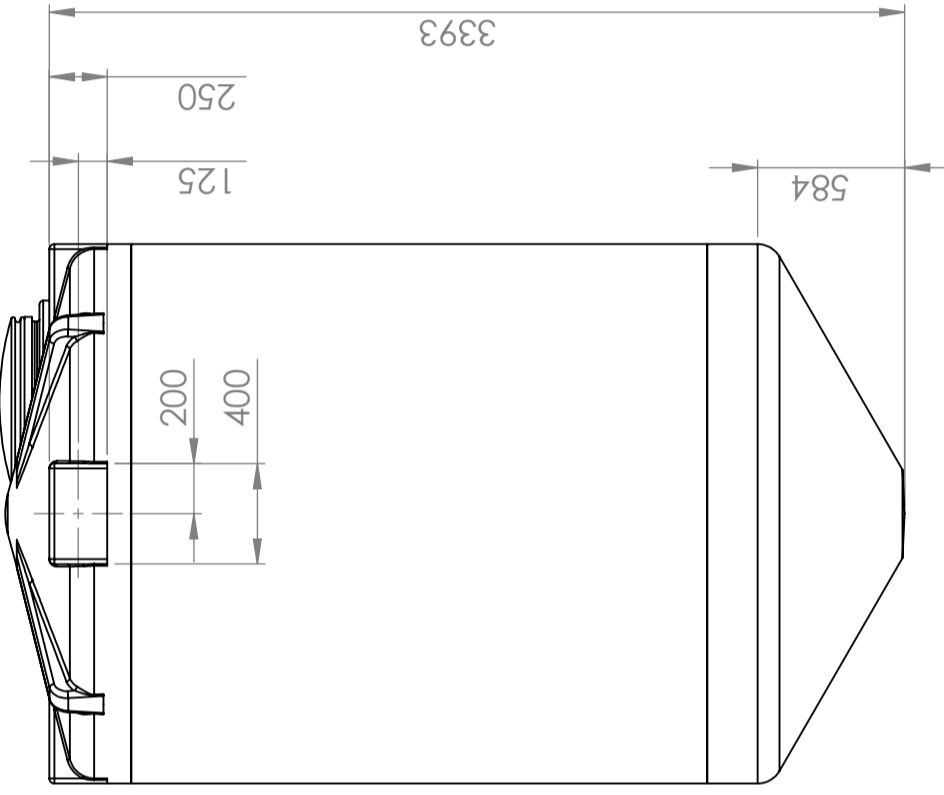
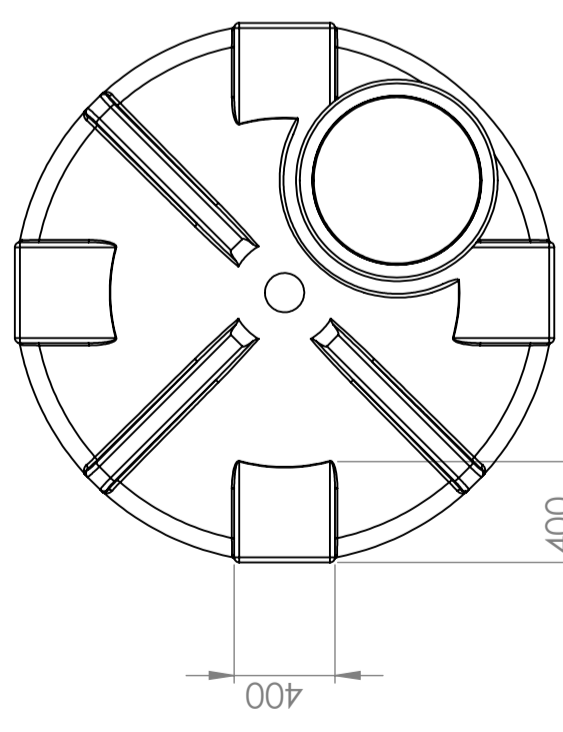
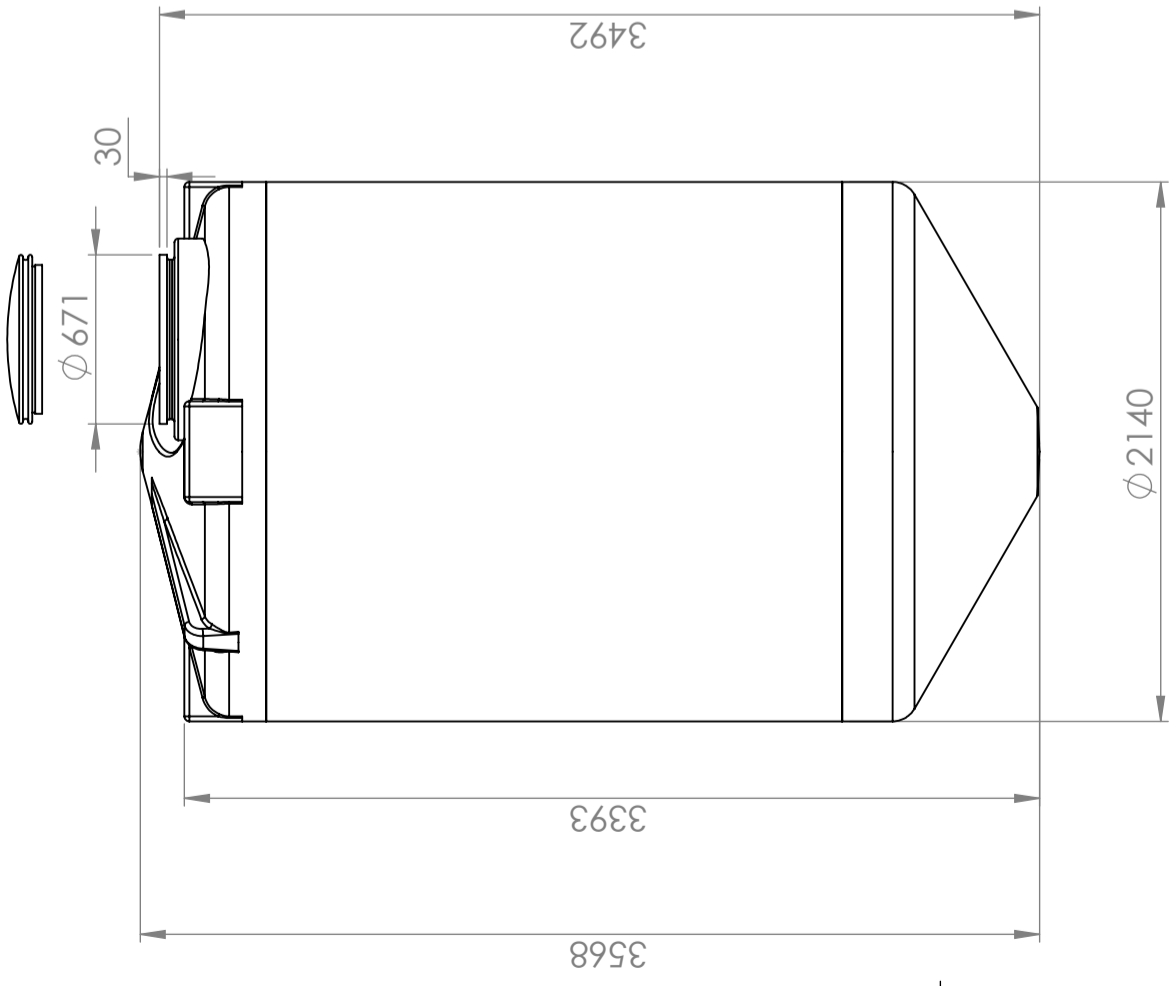

"Manhole requires 800 mm space to open fully. Compared to maximum height"

REVISIONS				
ZONE	REV.	DESCRIPTION	DATE	APPROVED
A	A	Renamed part to 1225741. Made a new drawing and updated views. M.P	22.04.2013	

Constructed by - date	Approved by - date	General Tolerances	Material	Finish, Ra	View	Scale
M.P 22.04.2013		NS-ISO 2768-1	LDPE	grit 120		1:30
Owner	Title/Description		10000 L Kon excentric			
	1225741		Drawing number			
	627 - 34		Revision			
			A			
			A3			
			Sheet			
			1(2)			

Generelle toleranser om ikke annet oppgitt på tegning	Tilatte avvik for måleområdet. Gjelder ved +20° C		
General tolerances if not other stated on drawing	Permissible deviations for basic length size range. Valid +20° C		
	0-20	>20-75	>75-150
	±0.5mm	±1mm	±1.5mm
		±1.3%	±1%
			>300
			±1%



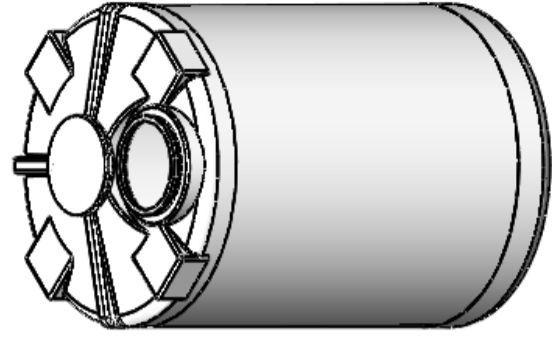
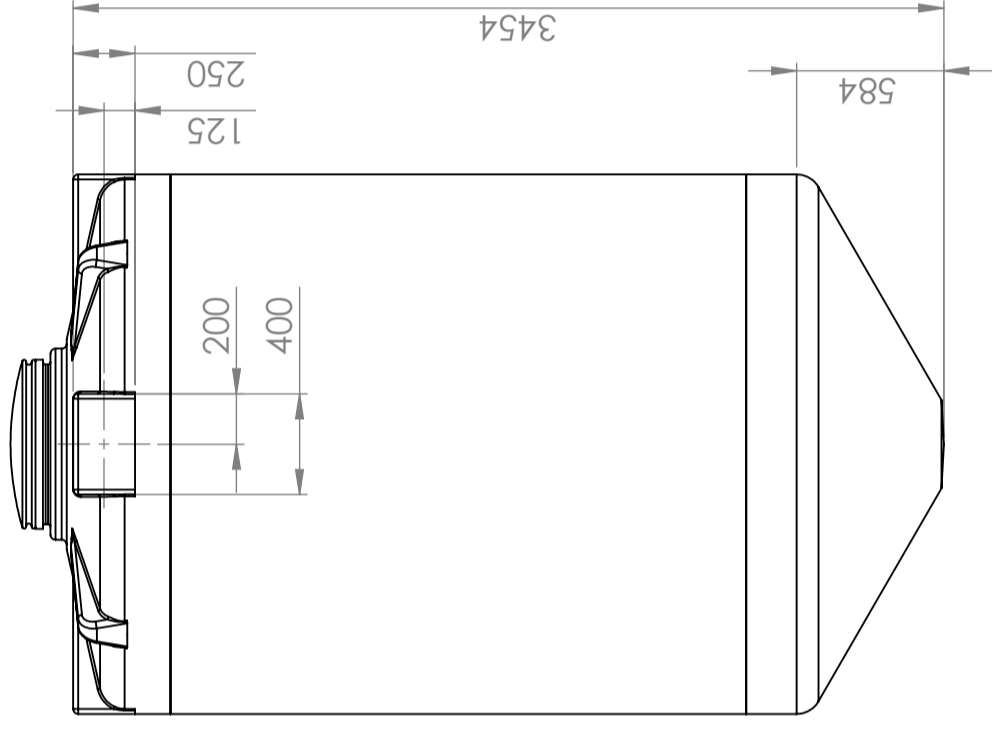
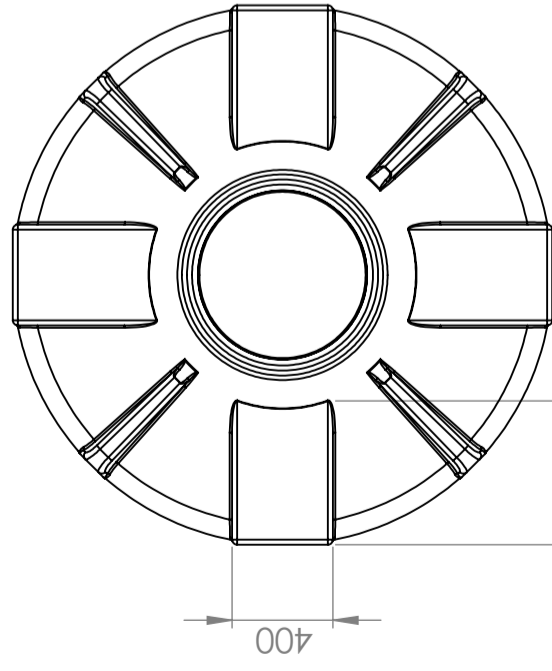
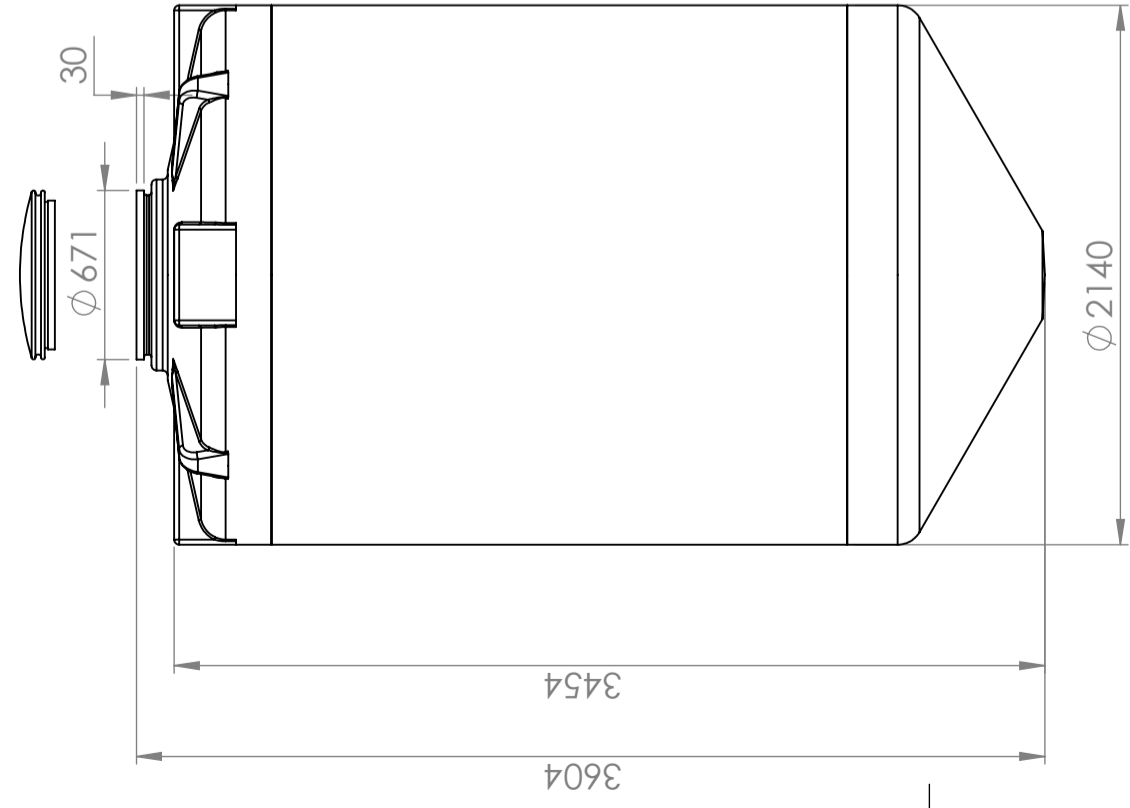

"Manhole requires 800 mm space to open fully. Compared to maximum height"

REVISIONS

ZONE	REV.	DESCRIPTION	DATE	APPROVED
-	A	Renamed part to 1225741. Made a new drawing and updated views. M.P	22.04.2013	-

Generelle toleranser om ikke annet oppgitt på tegning	Tilatte avvik for måleområde. Gjelder ved +20° C
General tolerances if not other stated on drawing	Permissible deviations for basic length size range. Valid +20° C
±0.5mm	0-20
±1mm	>20-75
±1.5mm	>75-150
±1.3%	>150-300
±1%	>300

Constructed by - date	Approved by - date	General Tolerances	Material	Finish, Ra	View	Scale
M.P 22.04.2013		NS-ISO 2768-1	LDPE	grit 120		1:30
Owner	Title/Description		10000 L Kon center			
	1225741		Drawing number			
	627 - 34		Revision			
	A		Sheet size			
	A3		Sheet			
	2(2)					



This drawing and design is the property of CIPAX. Copying and distribution of the drawing or any contents is prohibited without written permission from authorised personal at CIPAX.