

This drawing and design is the property of Cipax. Copying and distribution of the drawing or any contents is prohibited without written permission from authorised personal at Cipax

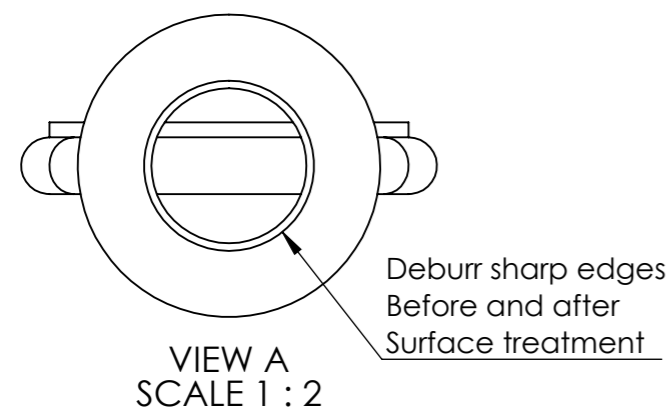
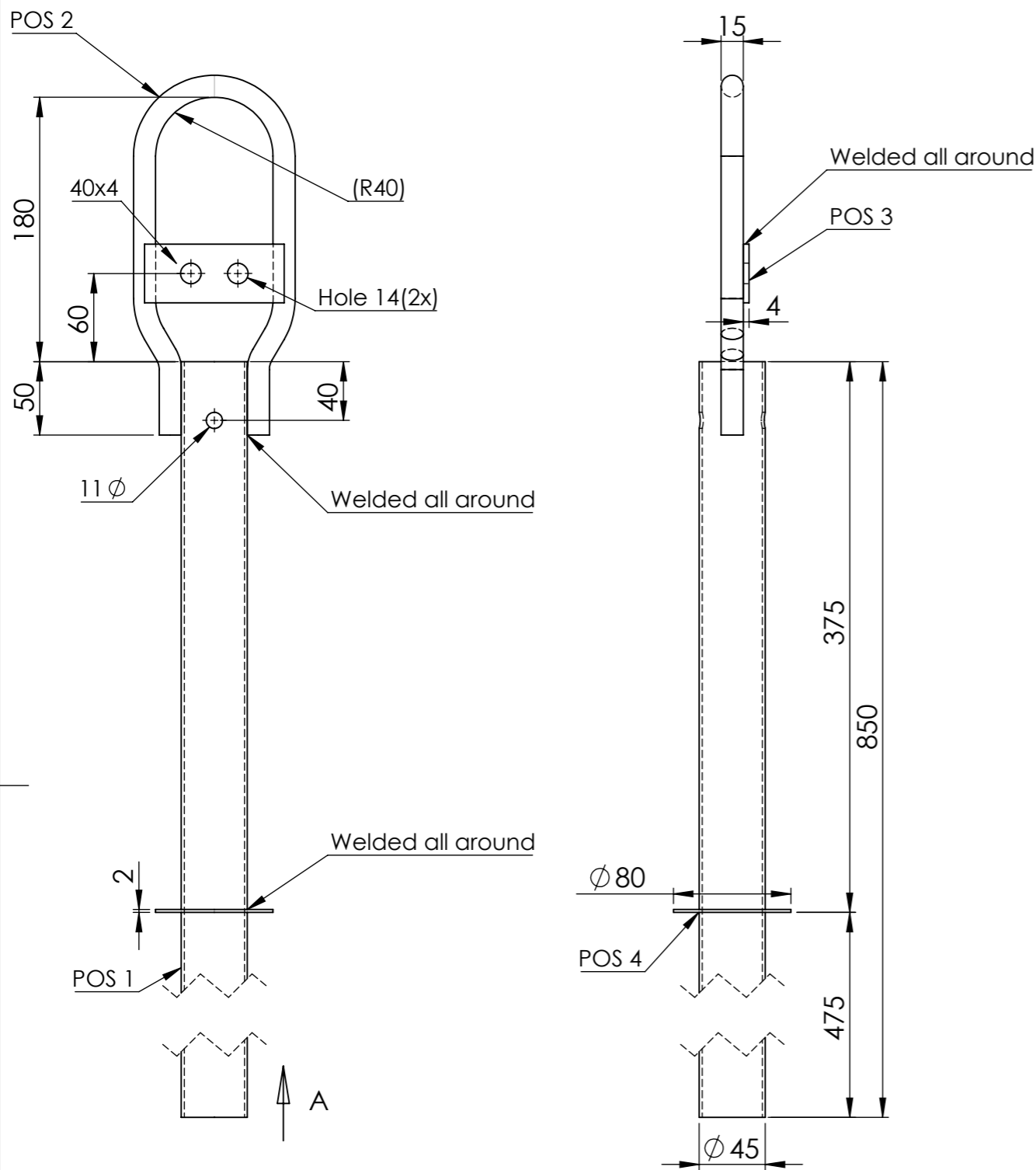

Revision			
Revision	Reason of change	Date	Approved

- POS 1
tube Material: EN 10305-3 (DIN 2394). t: 2 mm
- POS 2
rod Material: EN 10125 Fe 360B. ϕ 15
- POS 3
Plate Material: EN 10125 FE 360B. t: 4 mm
- POS 4
Plate Material: EN 10130 FeP01. t: 2 mm

Coating: Fe/Zn 115 ISO 1461.

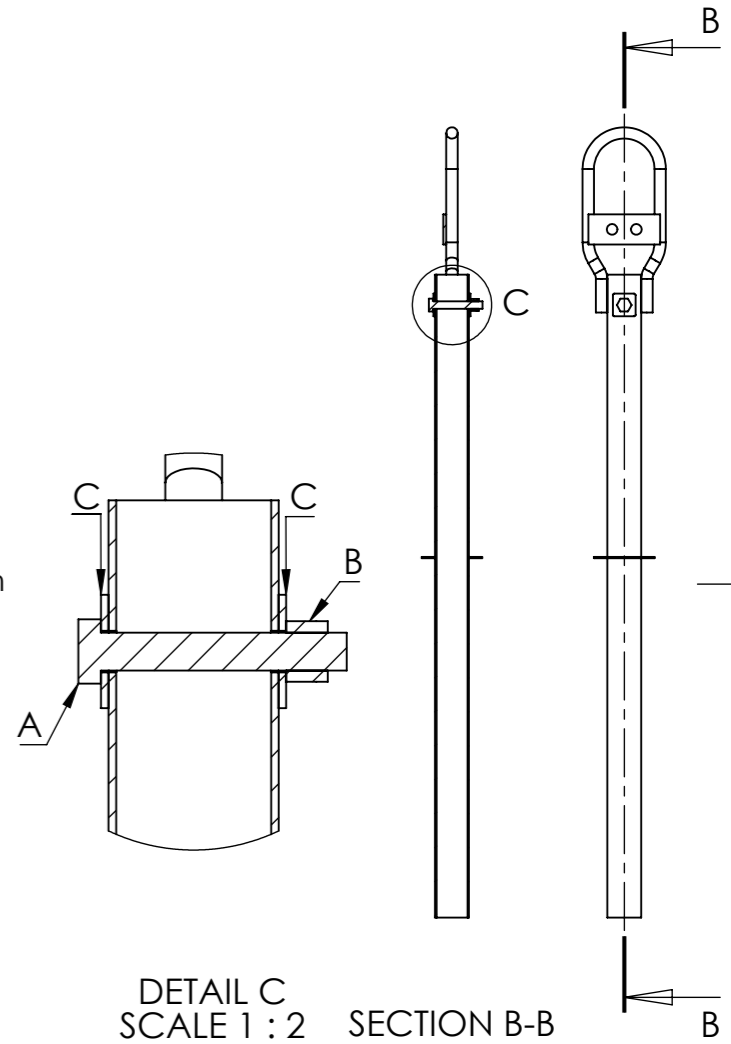

The bolt / nut / washer shall be assambled on each bouyrod

A		B		C	
Bolt ISO 4014 DIN 931 FZV	QTY	Nut DIN 985 FZV	QTY	Washer 30x30x3 S4B FZV DIN 436	QTY
M10 x 65 62353	1	M10 Nyloc 62355	1	62364	2

Designed by	Inspected by	Approved by - Date	General tolerance SS-ISO 2768-1	General surface finish, Ra	View position	Scale
		-	G			1:10
Owner			Titel/Name			
			Bojten 62201 35 LIT ϕ 45			
Drawing Number			Edition		Page	
62201			A		1(1)	