

1 2 3 4 5 6 7 8

A  
B  
C  
D  
E  
F

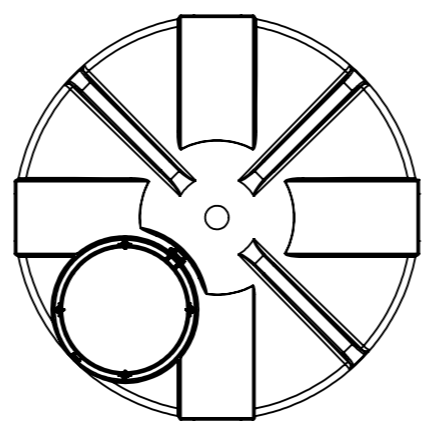
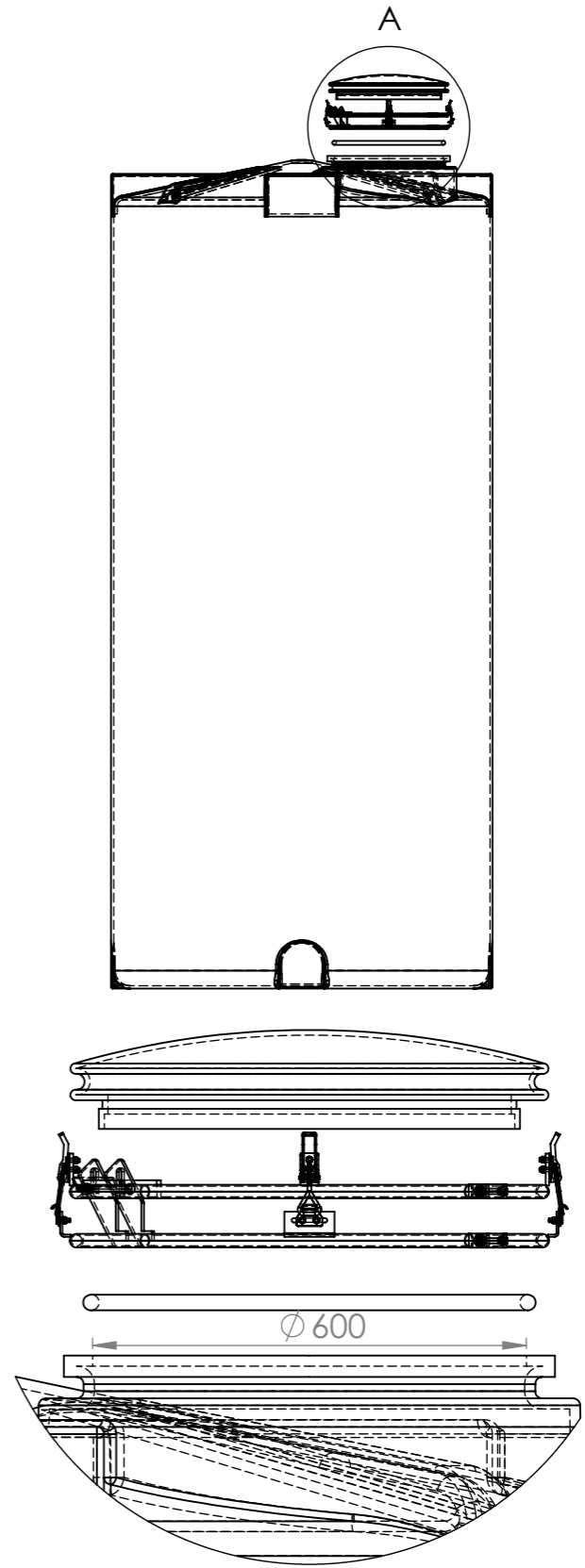
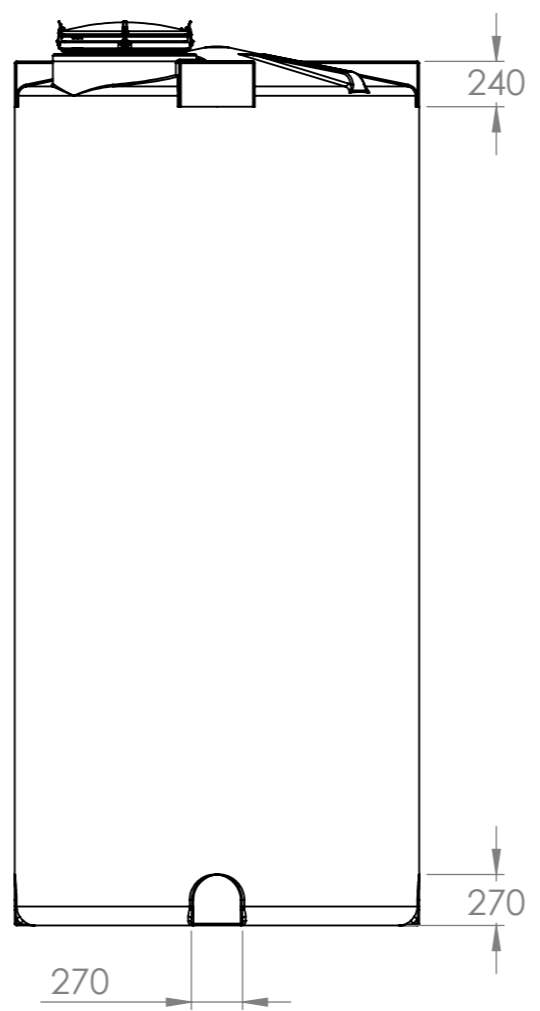
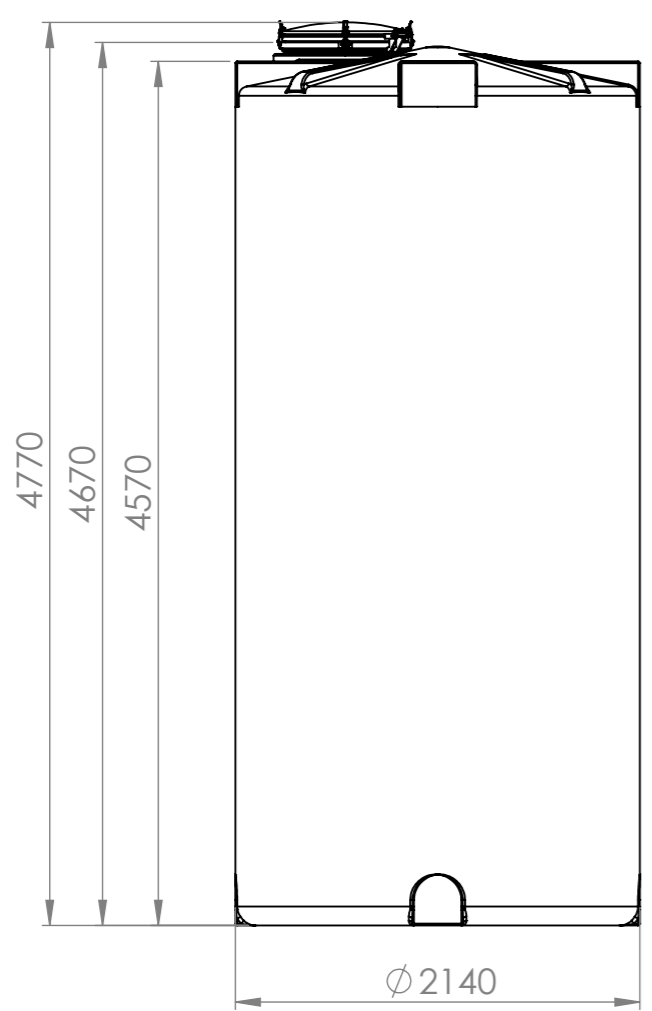

For tare weight 1.5 kg/dm<sup>3</sup>  
\*Manhole requires additional 800mm of height to fully open

Generelle toleranser om ikke annet er oppgitt på tegning	Tilatte avvik for måleområde. Gjelder ved +20°C				
General tolerances if not other stated on drawing	Permissible deviations for basic length size range. Valid +20°C				
	0-20	>20-75	>75-150	>150-300	>300
	±0,5mm	±1mm	±1,5mm	±1,3%	±1%

Constructed by - date	Evaluated by	Approved by - date	General Tolerances	Finish, Ra	View	Scale
GEP 18.03.2024			NS-ISO 2768-1	PE		1:40
Owner		Titel/Description		Revision		
		15013 CPX storage 15000L Natural				
Drawing number			Sheet size	Sheet		
1448 - 314			A3	1(2)		

1 2 3 4 5 6 7 8